

POWERNAIL® CO.

1300 Rose Road, Lake Zurich, IL 60047

Phone: 1-800-323-1653

Website: www.powernail.com

Operation and Maintenance Manual

MODEL 45R TONGUE AND GROOVE NAILER Ratcheting Nailer



WARNING

Read this manual before you use this Nailer. Follow all safety warnings and instructions. If you are uncertain about the operation of the Nailer, call us directly a 1-800-323-1653 for assistance or contact the closest Powernail dealer for help. Please retain this information for future reference.

MODEL 45R PARTS LIST

ITEM	PART NO.	DESCRIPTION	QTY. REQ'D.
1	08-45-00-010	SPRING CLIP	1
2	08-45-00-020	FEEDER CHANNEL	1
5	08-45-00-050	ROLLER PIN ASSEMBLY	1
5R	08-45-00-05R	ROLLER	1
13	08-45-00-130	FOOT SCREW	4
13N	08-45-00-13N	LOCKNUT	4
14	08-45-00-140	GATE	1
15	08-45-00-150	FOOT	1
16	08-45-00-960	SPRING CONTAINER SCREW	2
17	08-45-00-170	SPRING CONTAINER	1
18	08-45-00-180	FEEDER SPRING	1
19	08-45-00-930	SPRING CONTAINER LOCK WASHER	2
23	08-45-00-230	DOWEL PIN	2
25	08-45-00-250	HANDLE ASSEMBLY	1
29	08-45-00-290	ADAPTER PLATE PIN ASSEMBLY	1
37R	07-45-00-704	RATCHET PLUNGER	1
38	08-45-00-380	DRIVING BLADE	1
39	08-45-00-400	LEFT PLUNGER LINER	1
40R	08-45-00-705	RIGHT PLUNGER LINER	1
41	08-45-00-410	PLUNGER SPRING PIN	1
45	08-45-00-450	PLUNGER SPRING	1
58	08-45-00-580	BLADE RETAINER	1
59R	08-45R-00-59	RATCHET ASSEMBLY	1
60	08-45-00-710	RATCHET ACCESS PLATE	1
61	08-45-00-711	RATCHET ACCESS PLATE SCREW	2
400	06-99-400	TOE STAND	1
#8-25	06-99-010	#825 ADAPTER PLATE ASSEMBLY FOR 3/4" T&G	1

MODEL 45R ACCESSORIES

ITEM	PART NO.	DESCRIPTION	QTY. REQ'D.
#8-26	06-99-040	#826 ADAPTER PLATE ASSEMBLY FOR 1/2" T&G	1
#8-26	06-99-04A	#826 ADAPTER PLATE ASSEMBLY FOR 5/8" T&G	1
#8-25	06-99-04B	#825 ADAPTER PLATE ASSEMBLY FOR 22MM" T&G	1
70	06-99-720	#825 NO-MAR PAD (STICK-ON) .015 Thick	1
71	06-99-721	#825 NO-MAR PAD (STICK-ON) .060 Thick	1
72	08-45-TU-KIT	MODEL 45R TUNE-UP KIT	1
73	08-45R-OVH-KIT	MODEL 45R OVERHAUL KIT	1

MODEL 45R PARTS LIST

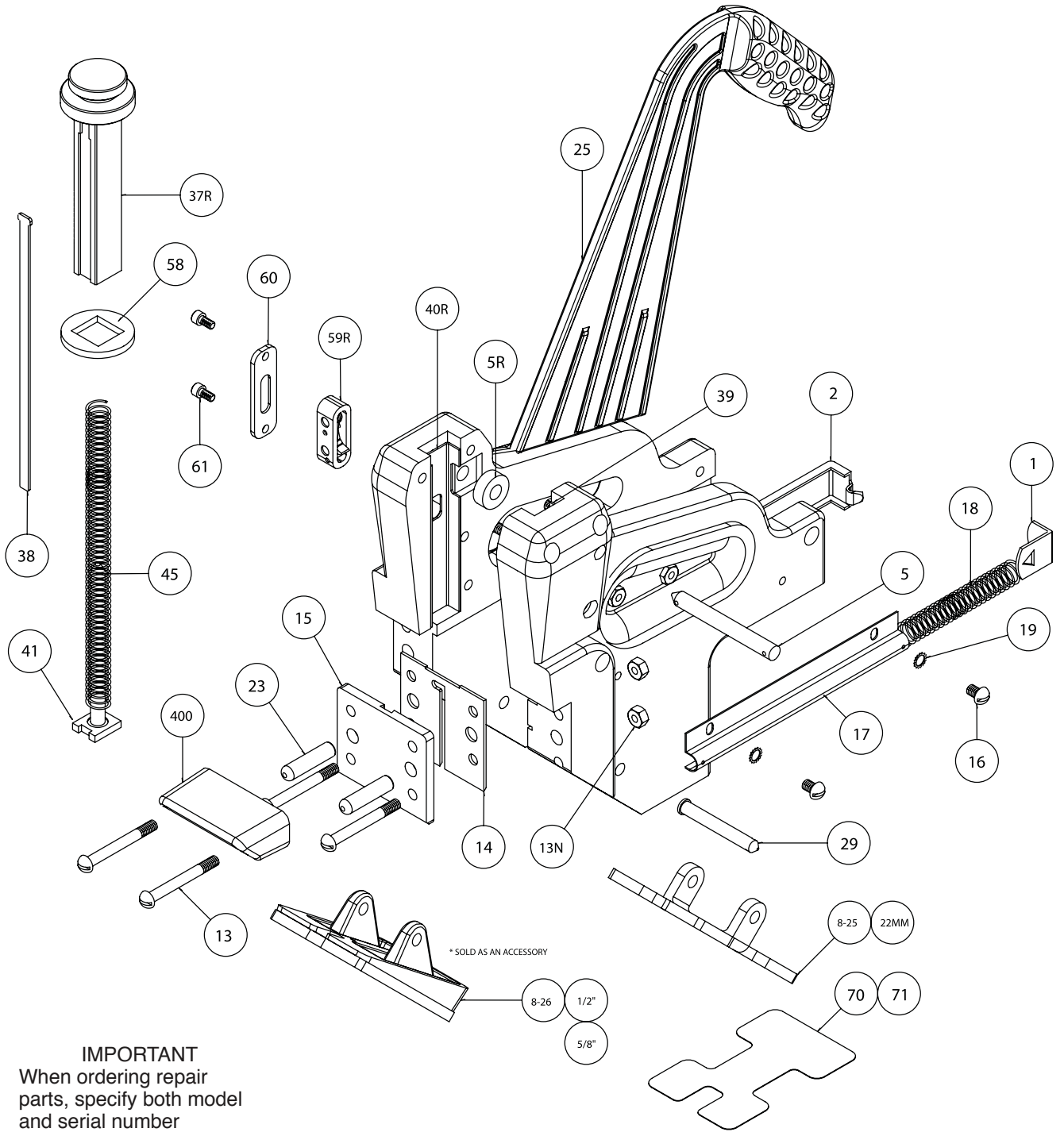

IMPORTANT
When ordering repair parts, specify both model and serial number

POWERCLEAT® NAIL LENGTH CHART

This chart will assist you in determining the proper length of Powercleat nails to use for various thicknesses of flooring when sub-flooring member varies as to species and thickness. Vertical penetration of the Powercleat nails under the hardwood floor is shown for each application. This is only a guide. Results should be tested in the field before proceeding.

2" Powercleats® 16 Gage

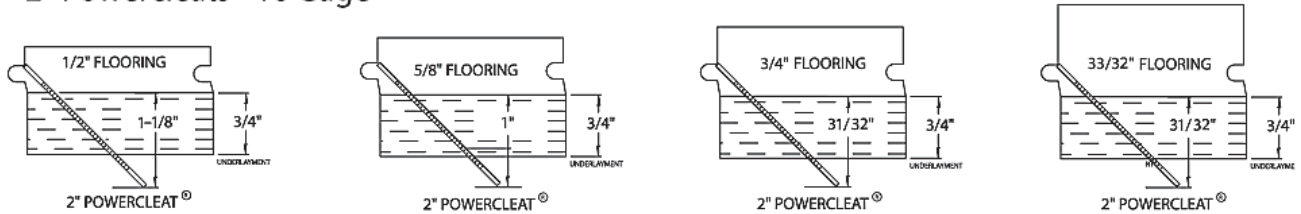

1-3/4" Powercleats® 16 Gage

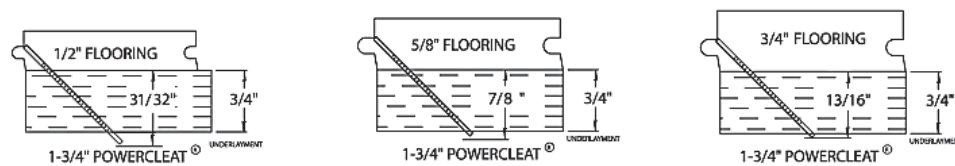

1-1/2" Powercleats® 16 Gage

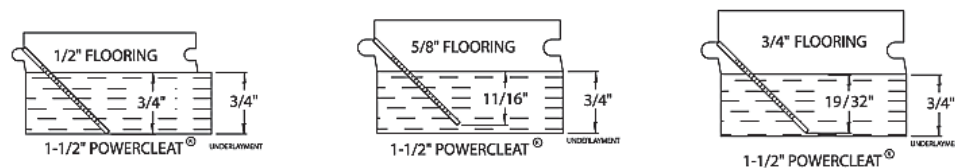

MODEL 45R & 101R RATCHET REPAIR INSTRUCTIONS

- With a 5/32 allen wrench, unscrew the two #10-32 socket head cap screws from the access plate.
- Remove access plate by turning nailer over.
- Remove ratchet insert assembly.
- Install new ratchet insert assembly as shown below.
- Replace access plate. Important: Make sure access plate is replaced as shown, with indent facing in towards ratchet.
- Fasten access plate back to body using a 5/32 allen wrench and the two socket head cap screws.

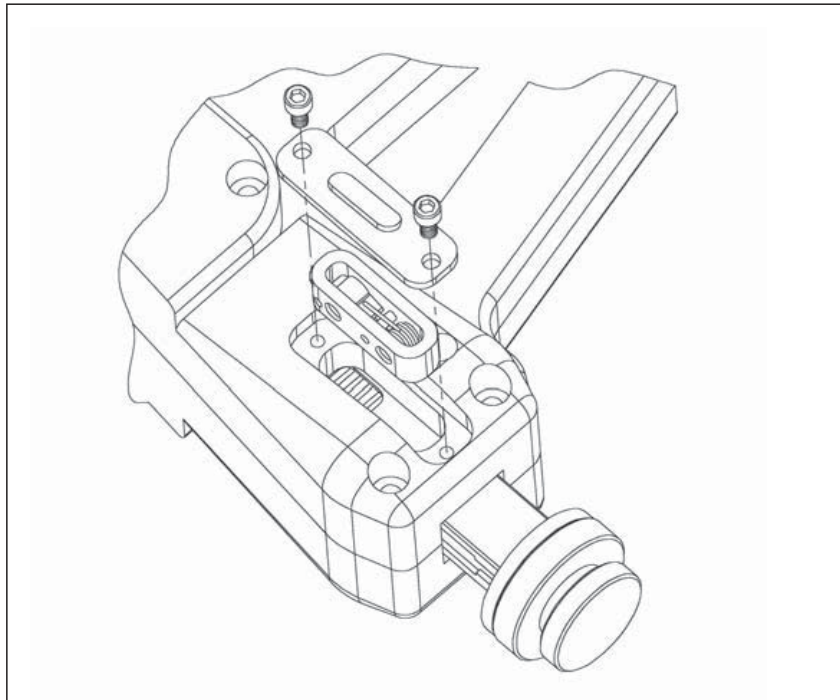

Adaptor Plates For Different Flooring Thicknesses

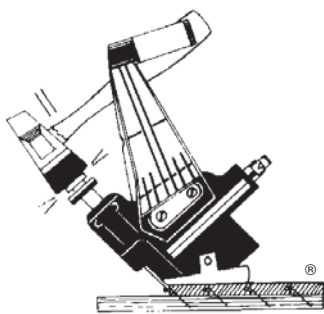

Model 45R flooring nailer fitted with 8-26 adaptor plate, to nail standard 1/2" T&G flooring.

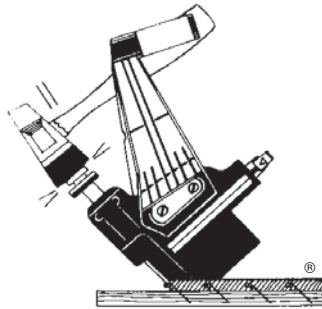

Model 45R flooring nailer without adaptor plates will nail standard 3/32" T&G flooring.

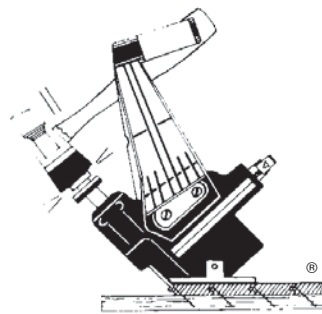

Model 45R flooring nailer fitted with 8-25 adaptor plate, to nail standard 25/32" T&G flooring.

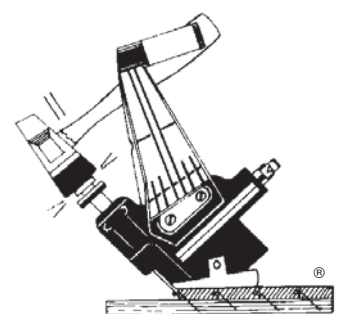

Model 45R flooring nailer fitted with 5/8" adaptor plate, to nail standard 5/8" T&G flooring.

REPLACING #38 DRIVING BLADE

1. Remove #5 Roller Pin—save Cotter Pin.
2. Holding Nailer in left hand with Nailer tilted so rear of Nailer is down, depress #37 Plunger Head slightly so #5R Roller is released from Plunger Head.
3. Remove #37 Plunger Head from Body of Nailer by lifting straight out of Body.
4. Remove #38 Driving Blade from under #58 Rubber Blade Retainer. Discard Blade.
5. Insert new #38 Driving Blade with face of Blade stamped "Front" facing front of Nailer, under #58 Rubber Blade Retainer until the "T" section at top of Blade fits into milled slot under Plunger Head. Push #58 Rubber Blade Retainer flush to underside of Plunger Head.
6. Holding Nailer in left hand with Nailer so rear of Nailer is down, slowly insert Plunger Head and Driving Blade Assembly into Nailer Body, making certain the #45 Plunger Spring is inserted into hole in Plunger Head.
7. While in this position, reinsert the #5 Roller Pin and Cotter Pin.
8. Installation is complete and Nailer is ready to use.

CAUTION

Using a mallet in the manner shown below will not only break the plunger head, but may also damage the nailer body to the point where factory repairs cannot be made.



IMPROPER MALLET USAGE WITH ALL POWERNAILER® NAILERS